



SPRINTER VAN

VAN SPECIFICATIONS

- Mercedes-Benz 3500 Sprinter Cargo Van—11,030-lb GVW
- Standard 2-Stage Turbo 4-Cylinder Diesel Engine with 7-Spd Transmission
- 3-Year / 36,000-Mile Manufacturer's Warranty on Van
- 5-Year / 100,000-Mile Manufacturer's Warranty on Diesel Engine
- Choice of 144" 170" or 170" Wheelbase with Extended Length
- Individual Cloth Covered Driver and Passenger Bucket Seats
- Premium Interior Trim Package Includes; Air Conditioning, Navigation, Satellite Ready Stereo and Back-up Camera
- Power Heated Mirrors and Electrically Heated Windshield

VAN CONFIGURATION & OPTIONS

- | | | |
|--|---|---|
| <p>Mast:</p> <ul style="list-style-type: none"> • 44' Pneumatic Heavy Duty Locking, with Rotating Base, 450-lb. Capacity (Standard) • Complete 2-Level, 4-Way Guy Kit & Protective Weather Cover Included <p>Generator:</p> <ul style="list-style-type: none"> • 10 kW Cummins Onan Diesel (Auto Start) • 1Ø 120 Volt 83.3 Amps • 1Ø 240 Volt 41.7 Amps • Automatic Transfer Switch • 100 AMP 6-Position 1Ø 3-Wire Dist. Panel • Locking Shore Power Tap Box with Color Coded Cam Lock Connections | <p>Van Upfit:</p> <ul style="list-style-type: none"> • 19" and 23" Equipment Rack with Integrated Battery Tray For Customer Installed Equipment • (4) Stabilizing Outriggers with 7,000-lb Jacks • 1" Foam Insulated Walls, Ceiling & Floor Areas Covered With ½" Plywood and Electrostatic Discharge Resistant Fabric and Slip Resistant Loncoin Vinyl Flooring • Ranger® Aluminum Front Cargo Partition With Locking Sliding Door To Rear of Vehicle • 15,000 BTU Roof Mounted HVAC Unit with Heat Strip • Ceiling Mounted LED Work Lights per Design • Purpose Built Roof-Mounted Work Platform with Weatherproof R/F Entry Port and Boarding Ladder | <p>Options/Add-ons:</p> <ul style="list-style-type: none"> • Automatic Hydraulic Vehicle Leveling System • 30' 150-lb. Capacity Mast in-lieu of 44' Mast • 60' 150-lb. Capacity Mast in-lieu of 44' Mast • Stainless Steel Topped Work Bench/Work Station with Secure Overhead Storage Compartment • 3-Sector Antenna Mounting System • Pan & Tilt Microwave Mount with Controller • Mid-Level Microwave Mount • Emergency Lighting Package, Flashers and Beacon • Equipment Installation/Integration |
|--|---|---|



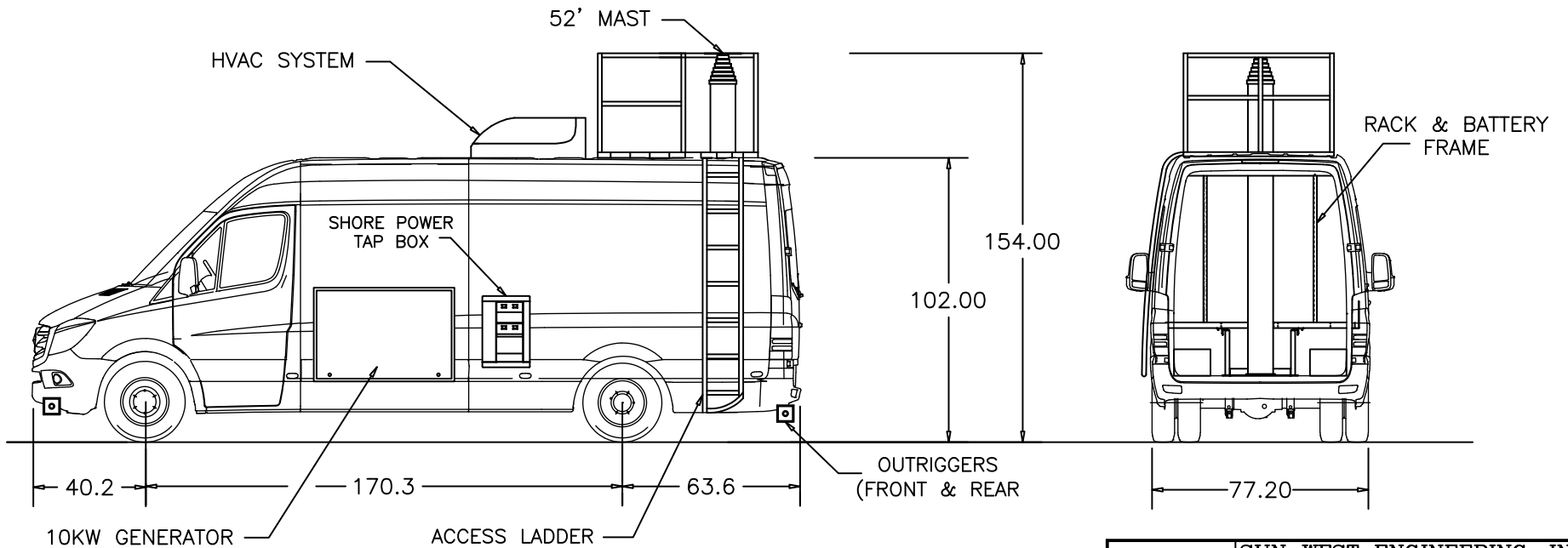
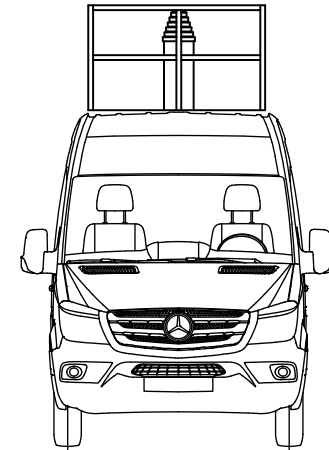
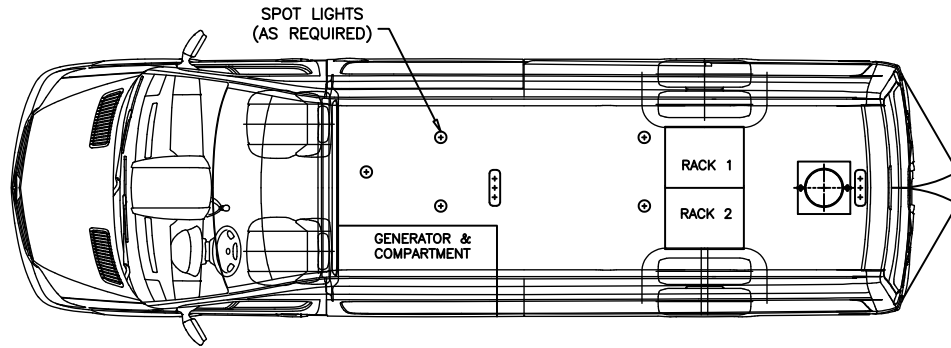

**PROPRIETARY
PROPOSAL**

**** PROPRIETARY AND CONFIDENTIAL ****
 Copyright © 2015 & Present Sun West Engineering, Inc.
 THIS PROPOSAL CONTAINS TRADE SECRETS AND
 OTHER PROPRIETARY AND CONFIDENTIAL
 INFORMATION OF SUN WEST ENGINEERING, INC.
 THIS DOCUMENTS AND ITS CONTENTS, INCLUDING
 WITHOUT LIMITATION THE DRAWINGS AND OTHER
 INFORMATION HEREIN, ARE THE SOLE AND EXCLUSIVE
 PROPERTY OF SUN WEST ENGINEERING, INC.
 ANY DUPLICATION, DISCLOSURE, OR USE OF ANY
 PORTION OF THIS DOCUMENT REQUIRES THE PRIOR
 WRITTEN CONSENT OF SUN WEST ENGINEERING, INC
 VIOLATIONS OF THESE TERMS SHALL BE
 PROSECUTED TO THE FULLEST EXTENT OF THE LAW

	SUN WEST ENGINEERING, INC. 3802 S. 38th ST., PHOENIX, AZ 85040 (602) 275-0662	
	TITLE: CARGO VAN – SPRINTER 170" WB	
CUSTOMER:		
PLOTTED SCALE: .XXXX=1	SHEET: 1 of 1	
DRAWN BY: <i>HJM</i>	DATE DRAWN: 3-28-16	
REVISED:	DWG. No. SW-5384	